

REV	REVISION RECORD	ECN	BY	APVL	DATE
-	NEW DRAWING	041107	NC	JMM	4/11/07
A	CHANGE DRW FORMAT TO SW AND MERGE INTO 1 PAGE. UPDATE REFERENCES.	C23-0278	MA	TT	1/3/23

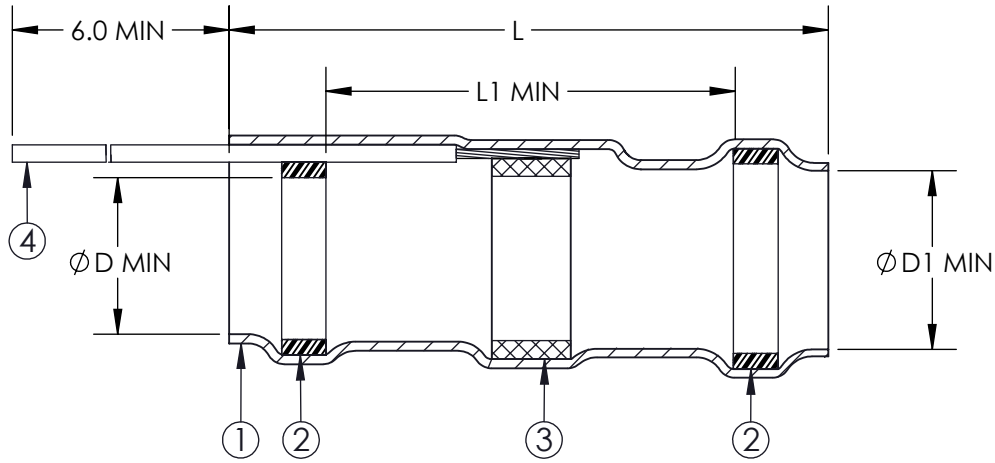

SAE AS83519/2 PART NUMBERS	MARKING CODE	SUMITOMO PART NUMBER	STS DIMENSIONS				CABLE MEASUREMENTS				
			L ±.070	L1 MIN	ØD MIN	ØD1 MIN	ØD2 MAX	ØD3 MIN	ØD4 MAX	ØD4 MIN	L2 ±.030
AS83519/2-1	S0201S	H-ML-1	0.650	0.325	0.075	0.105	0.105	0.035	0.075	0.020	.290
AS83519/2-2	S0202S	H-ML-2			0.105	0.145	0.145	0.055	0.105	0.030	
AS83519/2-3	S0203S	H-ML-3			0.170	0.200	0.200	0.085	0.170	0.050	
AS83519/2-4	S0204S	H-ML-4	.750	0.325	0.235	0.255	0.255	0.130	0.235	0.070	
AS83519/2-5	S0205S	H-ML-5			0.275	0.300	0.300	0.170	0.275	0.100	

**MATERIALS:**

- INSULATION SLEEVE: HEAT-SHRINKABLE, RADIATION CROSSLINKED, MODIFIED POLYVINYLIDENE FLUORIDE. COLOR = TRANSPARENT BLUE.
- MELTABLE SEALING RING: THERMALLY STABILIZED THERMOPLASTIC. COLOR= BLUE.
- SOLDER PREFORM: ALLOY - SN63 WITH RED THERMOCHROMIC INDICATOR, EUTECTIC AT 183° C, PER IPC-J-STD-006. FLUX: ROL 1 TYPE RMA FLUX FOR SILVER OR TIN APPLICATIONS, PER IPC-J-STD-004.
- PRE-INSTALLED WIRE LEAD PER MIL-W-22759/32-20-90.

**APPLICATION NOTES:**

- THESE PRODUCTS ARE TESTED AND QUALIFIED TO SAE AS83519/2 STANDARDS AND ARE LISTED ON THE QPL (CLASS I).
- PLEASE REFER TO THE SUMITOMO ELECTRIC STS INSTALLATION GUIDE FOR RECOMMENDED ASSEMBLY INFORMATION.
- TEMPERATURE RANGE: -55°C TO +150°C.

**RECOMMENDED CABLE PREPARATION**

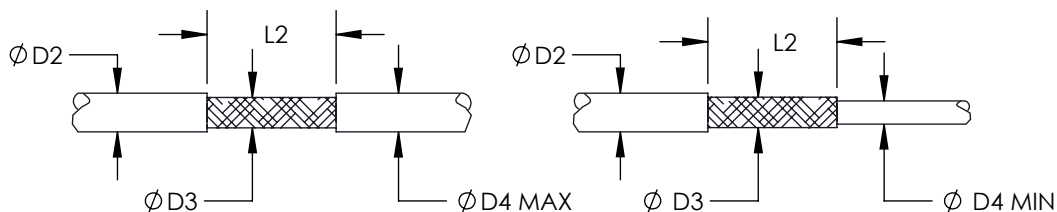

**AN SEIP STS PRODUCT**

UNLESS OTHERWISE SPECIFIED DIMENSIONS ARE IN INCHES	CAGECODE: 1JX75	<b>PROPRIETARY AND CONFIDENTIAL</b>			
	SIZE: A	THIS DRAWING AND ALL PARTS THEREOF IS AND SHALL REMAIN THE PROPERTY OF SEIP AND MAY NOT BE REPRODUCED FOR ANY PURPOSE WITHOUT SEIP WRITTEN CONSENT AND SHALL BE RETURNED TO US ON DEMAND. ALL RIGHTS RESERVED.			
TOLERANCES LINEAR .0 - N/A .00 - N/A .000 - N/A	SCALE: N/A	DCN: C23-0278	DRAWN BY: M AGUILAR	DATE: 1/3/23	
	REPLACES: H-ML-SAE AS83519/2 (1-5) REV.	CAD NO: HML[1-5]	APPROVED BY: TT	DATE: 1/3/23	



**SUMITOMO ELECTRIC INTERCONNECT PRODUCTS, INC.**

915 Armorlite Dr.  
San Marcos, CA 92069

DRAWING TITLE: SOLDER TERMINATION SLEEVE WITH PRE-INSTALLED LEAD, ENVIRONMENT RESISTANT, SAE AS83518/2 QUALIFIED	REV: A
DWG. NO.: H-ML-X (1-5) SAE AS83519/2	SHEET: 1-1