

DATE	REV	REVISION RECORD	REVISED BY	APPROVED BY
02-17-16	A	QPL SAE AS83519 APPROVAL	M AGUILAR	M AGUILAR

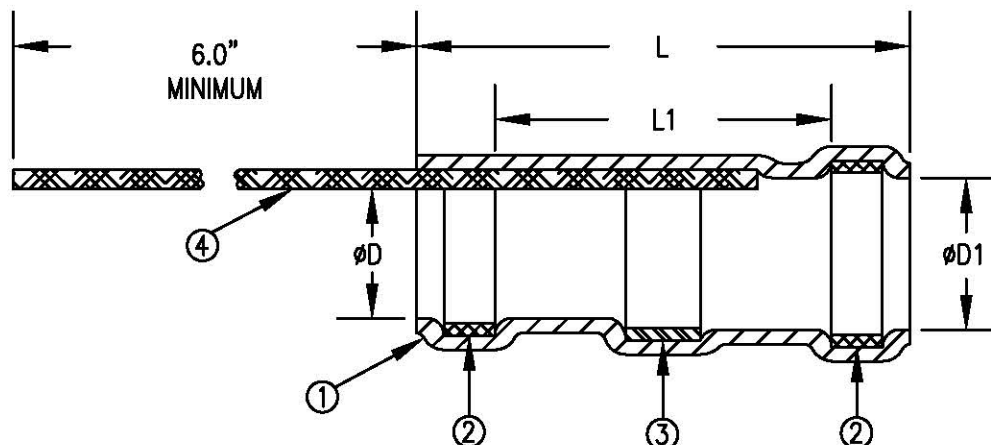

TABLE I: PRODUCT DETAILS

SAE AS83519/5 PART NUMBER	⑤ MARKING CODE *CLASS II NO "50" PREFIX	SUMITOMO PART NUMBER *CLASS II ADD -C2 SUFFIX	L ± .070	L1 MIN	ØD MIN	ØD1 MIN
AS83519/5-16	S0516S	H-HMB-16	.650	.325	.075	.105
AS83519/5-17	S0517S	H-HMB-17	.650	.325	.105	.145
AS83519/5-18	S0518S	H-HMB-18	.650	.325	.170	.200
AS83519/5-19	S0519S	H-HMB-19	.752	.325	.235	.255
AS83519/5-20	S0520S	H-HMB-20	.752	.325	.275	.300

MATERIALS:

- ① INSULATION SLEEVE:
HEAT-SHRINKABLE, RADIATION CROSSLINKED, MODIFIED POLYVINYLIDENE FLUORIDE.
COLOR = TRANSPARENT BLUE.
- ② MELTABLE SEALING RING:
THERMALLY STABILIZED THERMOPLASTIC. COLOR = 2 BLUE
- ③ SOLDER PREFORM:
ALLOY - Sn96 WITH RED THERMOCHROMIC INDICATOR, MELTS AT 221°C. PER ANSI-J-STD-006.
*(CLASS II = NO RED THERMOCHROMIC INDICATOR)
FLUX - ROM1 TYPE RA FLUX FOR NICKEL APPLICATIONS. PER ANSI-J-STD-004.
- ④ PRE-INSTALLED BRAID, FLAT, NICKEL PLATED STRANDS, 1200CMA, PER AA59569F36N0062, PRE-TINNED.
- ⑤ MARKING CODE APPLIED TO SLEEVE.

DIMENSIONS ARE IN INCHES TOLERANCES: (EXCEPT AS NOTED)		 915 ARMORLITE DR., SAN MARCOS, CA 92069	
LINEAR 0.0 = N/A 0.00 = N/A 0.000 = N/A	ANGULAR 0° = N/A 0°0' = N/A 0°00' = N/A		
An STS PRODUCT		TITLE: SOLDER TERMINATION SLEEVE WITH PRE-INSTALLED BRAID ENVIRONMENTAL RESISTANT. SAE AS83519/5 QUALIFIED.	
DRAWN D. SHOUDY	02-10-15	DRAWING NUMBER: H-HMB-X SAE AS83519/5 (16-20)	
APPROVED M. JOHNSON	02-10-15	REV A	
OTHER REF. SAE AS83519/5 (8-10)	ORIG. DATE 02-10-15	SCALE: NONE	CAD NO. H-HMB-X SAE AS83519/5 (28-20)
		SHEET 1 OF 2	

RECOMMENDED CABLE PREPARATIONS:

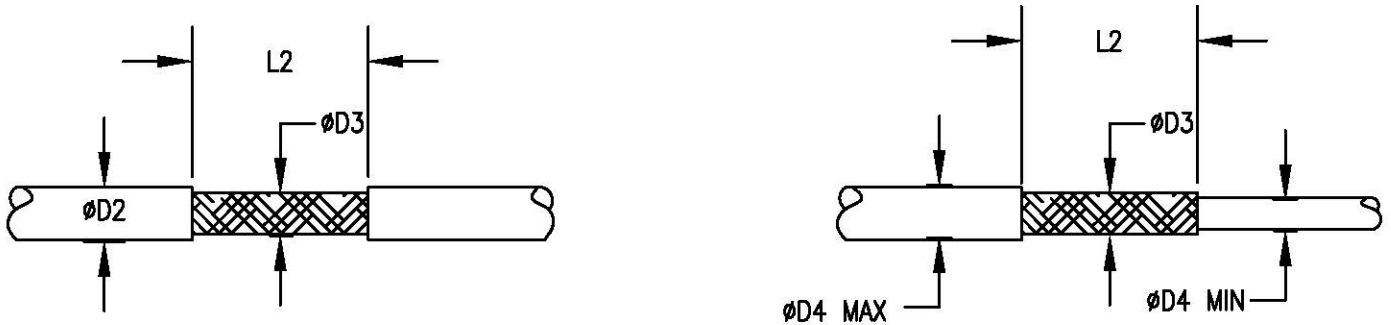



TABLE II: CABLE PREPARATION MEASUREMENTS

SUMITOMO PART NUMBER	$\phi D2$ MAXIMUM	$\phi D3$ MINIMUM	$\phi D4$ MAXIMUM	$\phi D4$ MINIMUM	L2 RANGE
H-HMB-16	.075	.035	.105	.020	.270-.330
H-HMB-17	.105	.055	.145	.030	.270-.330
H-HMB-18	.170	.085	.200	.050	.270-.330
H-HMB-19	.235	.130	.255	.070	.270-.330
H-HMB-20	.275	.169	.300	.100	.270-.330

NOTES:

- PLEASE REFER TO THE SUMITOMO ELECTRIC STS INSTALLATION GUIDE FOR RECOMMENDED ASSEMBLY INFORMATION.
- TEMPERATURE RANGE: -55°C TO $+175^{\circ}\text{C}$.

 SUMITOMO ELECTRIC INTERCONNECT PRODUCTS, INC.		
915 ARMORLITE DR., SAN MARCOS, CA 92069		
TITLE: SOLDER TERMINATION SLEEVE WITH PRE-INSTALLED BRAID ENVIRONMENTAL RESISTANT. SAE AS83519/5 QUALIFIED.		
DRAWING NUMBER: H-HMB-X SAE AS83519/5 (16-20)		REV A
SCALE: NONE	CAD NO. H-HMB-X SAE AS83519/5 (16-20)	SHEET 2 OF 2