

DATE	SYM	REVISION RECORD	AUTH	DR
10-15-07	A	PRE-INSTALLED LEAD WIRE CHANGED TO -90 COLOR CODE	JMM	NNC

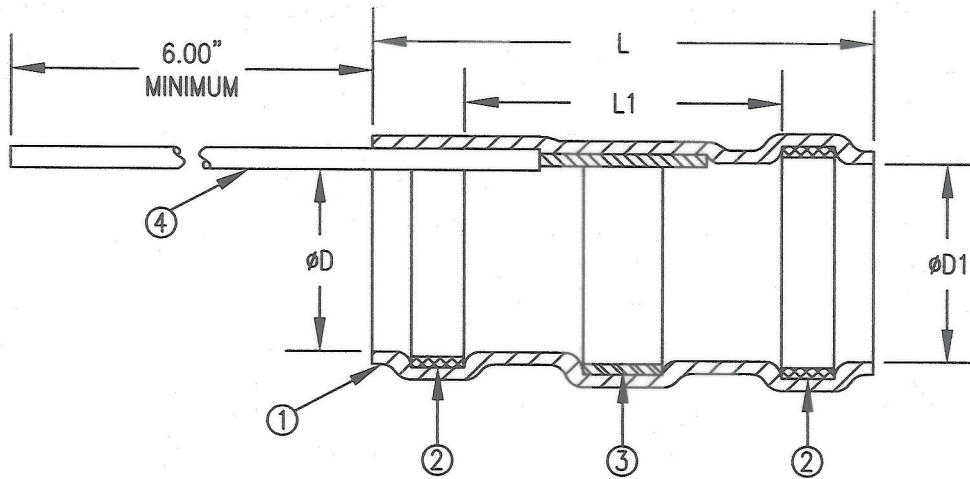

TABLE I: PRODUCT DETAILS

SUMITOMO PART NUMBER	L ± .070	L1 MINIMUM	ØD MINIMUM	ØD1 MINIMUM
H-HML-1	.650	.325	.075	.105
H-HML-2	.650	.325	.105	.145
H-HML-3	.650	.325	.170	.200
H-HML-4	.750	.325	.235	.255
H-HML-5	.750	.325	.275	.300

MATERIALS:

- ① INSULATION SLEEVE:
HEAT-SHRINKABLE, RADIATION CROSSLINKED, MODIFIED POLYVINYLIDENE FLUORIDE.
COLOR = TRANSPARENT BLUE.
- ② MELTABLE SEALING RING:
THERMALLY STABILIZED THERMOPLASTIC. COLOR = 2 BLUE.
- ③ SOLDER PREFORM:
ALLOY - Sn96 WITH RED THERMOCHROMIC INDICATOR, MELTING POINT AT 221°C. PER ANSI-J-STD-006.
FLUX - ROM1 TYPE RA FLUX FOR NICKEL APPLICATIONS. PER ANSI-J-STD-004.
- ④ PRE-INSTALLED WIRE LEAD PER MIL-W-22759/41-20-90

DIMENSIONS ARE IN INCHES		<p>915 ARMORLITE DR., SAN MARCOS, CA 92069</p>	
TOLERANCES: (EXCEPT AS NOTED)			
LINEAR	ANGULAR	TITLE: SOLDER TERMINATION SLEEVE WITH PRE-INSTALLED LEAD	
0.0 = N/A	0° = N/A		
0.00 = N/A	0°0' = N/A		
0.000 = N/A	0°00' = N/A	DRAWING NUMBER: H-HML-X (1-5)	
An STS PRODUCT		REV A	
DRAWN N. CANADAY	10-15-07	SCALE: NONE	
APPROVED <i>Jon M. Mills</i>	10-15-07	CAD NO. H-HML-X (1-5)	
OTHER REF.	ORIG. DATE 06-19-07	SHEET 1 OF 2	

DO NOT COPY

DATE	SYM	REVISION RECORD	AUTH	DR
10-15-07	A	PRE-INSTALLED LEAD WIRE CHANGED TO -90 COLOR CODE	JMM	NNC

RECOMMENDED CABLE PREPARATIONS:



TABLE II: CABLE PREPARATION MEASUREMENTS

SUMITOMO PART NUMBER	$\phi D2$ MAXIMUM	$\phi D3$ MINIMUM	$\phi D4$ MAXIMUM	$\phi D4$ MINIMUM	L2 RANGE
H-HML-1	.105	.035	.075	.020	.250-.325
H-HML-2	.145	.055	.105	.030	.250-.325
H-HML-3	.200	.085	.170	.050	.250-.325
H-HML-4	.255	.130	.235	.070	.250-.325
H-HML-5	.300	.170	.275	.100	.250-.325

NOTES:

- PLEASE REFER TO THE SUMITOMO ELECTRIC STS INSTALLATION GUIDE FOR RECOMMENDED ASSEMBLY INFORMATION.
- TEMPERATURE RANGE: -55°C TO +175°C.

DIMENSIONS ARE IN INCHES TOLERANCES: (EXCEPT AS NOTED)			
LINEAR 0.0 = N/A 0.00 = N/A 0.000 = N/A	ANGULAR 0° = N/A 0°0' = N/A 0°00' = N/A	915 ARMORLITE DR., SAN MARCOS, CA 92069	
An STS PRODUCT		TITLE: SOLDER TERMINATION SLEEVE WITH PRE-INSTALLED LEAD	
DRAWN N. CANADAY 10-15-07 APPROVED <i>Jon M. Mills</i> 10-15-07 OTHER REF.	ORIG. DATE 06-19-07	DRAWING NUMBER: H-HML-X (1-5)	REV A
SCALE: NONE		CAD NO. H-HML-X (1-5)	SHEET 2 OF 2

DO NOT COPY

OCT 18 2007

ISSUED