

DATE	SYM	REVISION RECORD	AUTH	DR

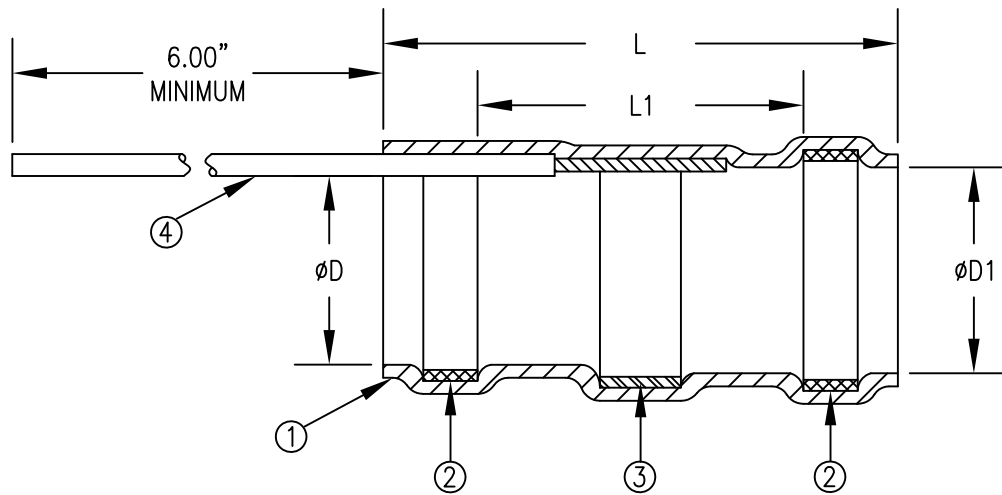

TABLE I: PRODUCT DETAILS

SUMITOMO PART NUMBER	L ± .070	L1 MINIMUM	∅D MINIMUM	∅D1 MINIMUM
H-HML-11-YY	.650	.325	.075	.105
H-HML-12-YY	.650	.325	.105	.145
H-HML-13-YY	.650	.325	.170	.200
H-HML-14-YY	.750	.325	.235	.255
H-HML-15-YY	.750	.325	.275	.300

WIRE COLOR CODES (YY)
PER MIL-STD-681

DESIGNATOR	COLOR
0	BLACK
1	BROWN
2	RED
3	ORANGE
4	YELLOW
5	GREEN
6	BLUE
7	PURPLE
8	GRAY
9	WHITE

MATERIALS:

- ① INSULATION SLEEVE:
HEAT-SHRINKABLE, RADIATION CROSSLINKED, MODIFIED POLYVINYLIDENE FLUORIDE.
COLOR = TRANSPARENT BLUE.
- ② MELTABLE SEALING RING:
THERMALLY STABILIZED THERMOPLASTIC. COLOR = 2 BLUE.
- ③ SOLDER PREFORM:
ALLOY - Sn96 WITH RED THERMOCHROMIC INDICATOR, MELTING POINT AT 221°C. PER ANSI-J-STD-006.
FLUX - ROM1 TYPE RA FLUX FOR NICKEL APPLICATIONS. PER ANSI-J-STD-004.
- ④ PRE-INSTALLED WIRE LEAD PER MIL-W-22759/41-24-YY

DIMENSIONS ARE IN INCHES		<p>915 ARMORLITE DR., SAN MARCOS, CA 92069</p>	
TOLERANCES: (EXCEPT AS NOTED)			
LINEAR	ANGULAR	TITLE: SOLDER TERMINATION SLEEVE WITH PRE-INSTALLED LEAD DRAWING NUMBER: H-HML-X-YY (11-15)	
0.0 = N/A	0° = N/A		
0.00 = N/A	0°0' = N/A		
0.000 = N/A	0°00' = N/A	REV -	
An STS PRODUCT		DRAWING NUMBER: H-HML-X-YY (11-15)	
DRAWN	N. CANADAY	03-30-07	SCALE: NONE
APPROVED	<i>Jon M. Mills</i>	03-30-07	CAD NO. H-HML-X-YY (11-15)
OTHER REF.	ORIG. DATE	03-30-07	SHEET 1 OF 2

DATE	SYM	REVISION RECORD	AUTH	DR

RECOMMENDED CABLE PREPARATIONS:

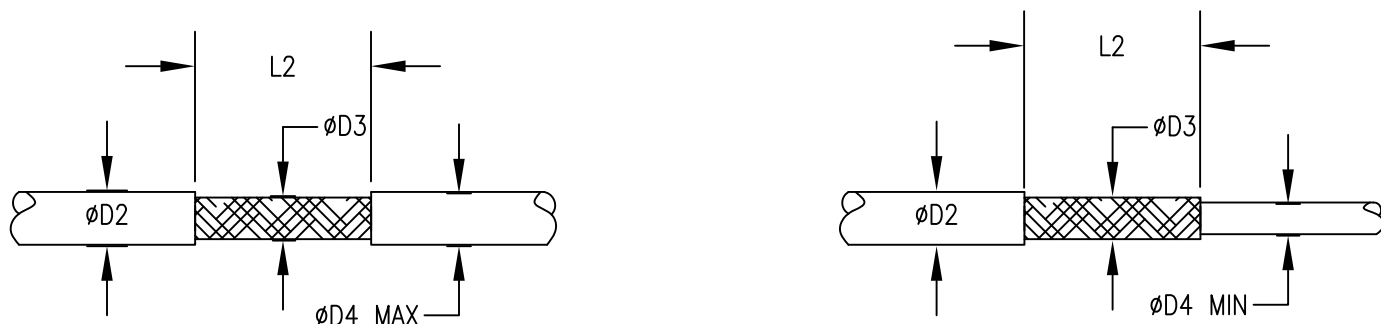



TABLE II: CABLE PREPARATION MEASUREMENTS

SUMITOMO PART NUMBER	$\phi D2$ MAXIMUM	$\phi D3$ MINIMUM	$\phi D4$ MAXIMUM	$\phi D4$ MINIMUM	L2 RANGE
H-HML-11-YY	.105	.035	.075	.020	.250-.325
H-HML-12-YY	.145	.055	.105	.030	.250-.325
H-HML-13-YY	.200	.085	.170	.050	.250-.325
H-HML-14-YY	.255	.130	.235	.070	.250-.325
H-HML-15-YY	.300	.170	.275	.100	.250-.325

NOTES:

- PLEASE REFER TO THE SUMITOMO ELECTRIC STS INSTALLATION GUIDE FOR RECOMMENDED ASSEMBLY INFORMATION.
- TEMPERATURE RANGE: -55°C TO +175°C.

DIMENSIONS ARE IN INCHES		 SUMITOMO ELECTRIC INTERCONNECT PRODUCTS, INC. 915 ARMORLITE DR., SAN MARCOS, CA 92069		
TOLERANCES: (EXCEPT AS NOTED)				
LINEAR	ANGULAR	TITLE: SOLDER TERMINATION SLEEVE WITH PRE-INSTALLED LEAD DRAWING NUMBER: H-HML-X-YY (11-15) REV -		
0.0 = N/A	0° = N/A			
0.00 = N/A	0°0' = N/A			
0.000 = N/A	0°00' = N/A	An STS PRODUCT DRAWING NUMBER: H-HML-X-YY (11-15) REV -		
DRAWN	N. CANADAY	03-30-07	SCALE: NONE	
APPROVED	Jon M. Mills	03-30-07	CAD NO. H-HML-X-YY (11-15)	
OTHER REF.	ORIG. DATE	03-30-07	SHEET 2 OF 2	